

CBO155HP101-428A12

Product Specification For Inductive Common Mode Nanotech® Cores



MH&W International Corp.

575 Corporate Drive, Suite 4200, Mahwah, NJ 07430 USA

Phone 201-252-8125 Email: sales@mhw-intl.com

Mechanical Specification

Bare Core Dimensions:

6.30 x 5.12 x 1.18 inch
(160 x 130 x 30 mm)

le: 44.7 cm

Ae: 3.3 cm²

Weight: 2.7 lbs (1200 grams)

Packing: 1 pc/layer, 5 layers/box

Box Quantity: 5 pieces

Core Material: Nanocrystalline

Currie Temp: 1,112°F (600 °C)

RTI Temp (0.81): 248°F (120°C)

Marking:

CBO155HP101-428A12

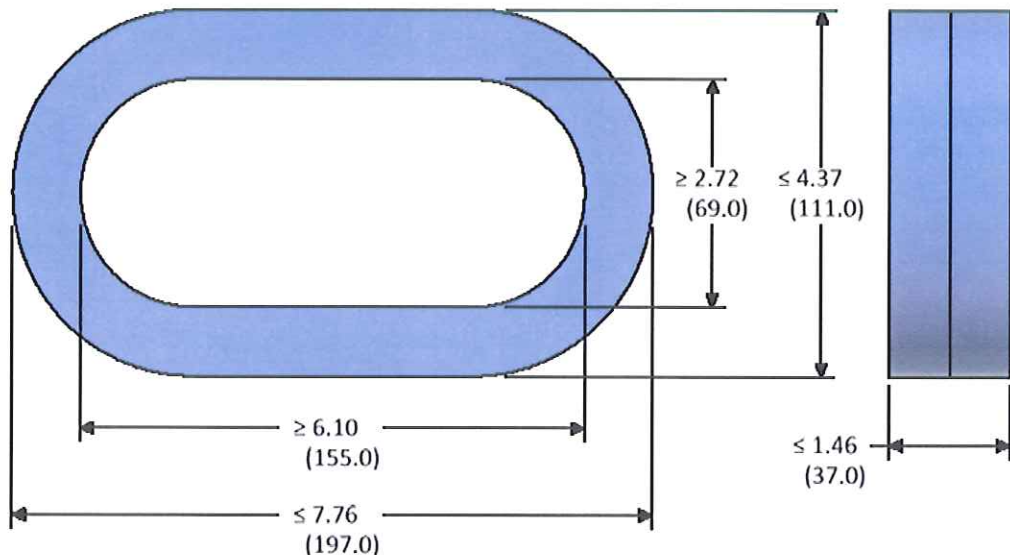

Dimensions = inches (mm)

Electrical Core Performance

Permeability @ frequency = 10 KHz and Hpeak = 3.10 mA/cm ~30,000

Inspection Value	Measured Value	Measurement Limits	Frequency	L _{eff} * N (mA*turn)	Maximum Asymmetric Current I _{sat} * (Sum Peak Current)
	A _L (μH/N ²)	20.9 - 45.0	10 KHz	100	
A _L (μH/N ²)	10.5 min	100 KHz	100		

*Saturation Current (Isat) of nanocrystalline material: Peak value of the exiting current when the initial inductance level is dropped to 10 per cent. Saturation behaviour is dependant on frequency, signal shape and leakage field. The current value is a calculated value for design help only and cannot be guaranteed. Isat is calculated @ B = 1.0 T - μnom - N = 1.

Core Finishing

Type:	Plastic Case	Case Material Alternatives:	Zytel FR70G25	Rynite FR530	Longlite 4130	PA66-R11G25
Voltage Breakdown:	2,500 VRMS	Case UL file Number:	E41938	E41938	E59481	E484599

Certification

MH&W International certifies that the manufacturing and the quality process meet all requirements of IEC Part 1: General Specification for "Fixed Inductors For Electromagnetic Interference Suppression", IEC 60938-1:1999 + A1:2006. This International Standard is used in lieu of requirements/documents pertaining to UL, CE, CSA, DIN and other individual agencies. The flame insulation rating meets UL-94V-0.

MH&W International certifies the product described herein is in compliance with the Directive 2011/65/EU of the European Parliament and of the council of 8 June, 2011 on the Restriction of the use of Certain Hazardous Substances in Electrical and Electronic Equipment (RoHS2 Directive).

Rev #	Date	Description	Drawing Approval	Drawing Number
2	08/17/17	Initial Issue	Engineering: D. Rollins	CBO155HP101-428A12 R3
3	05/03/21	Updated to new datasheet format.	Sales: B. Wilson	

N57HP103-428

Product Specification For Inductive Differential Mode Nanotech® Cores



MH&W International Corp.

575 Corporate Drive, Suite 4200, Mahwah, NJ 07430 USA

Phone 201-252-8125 Email: sales@mhw-intl.com

Mechanical Specification

Bare Core Dimensions:

3.15 x 2.48 x 1.18 inch
(80 x 63 x 30 mm)

le: 22.36 cm

Ae: 1.86 cm²

Weight: 0.74 lbs 335 grams)

Packing: 6 pc/layer, 2 layers/box

Box Quantity: 12 pieces

Core Material: Nanocrystalline

Currie Temp: 1,112°F (600 °C)

RTI Temp (0.81): 248°F (120°C)

Marking:

N57HP103-428

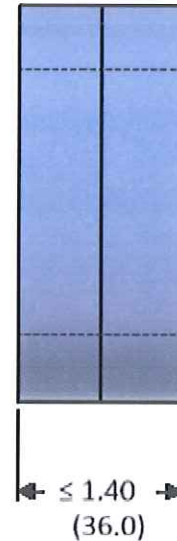
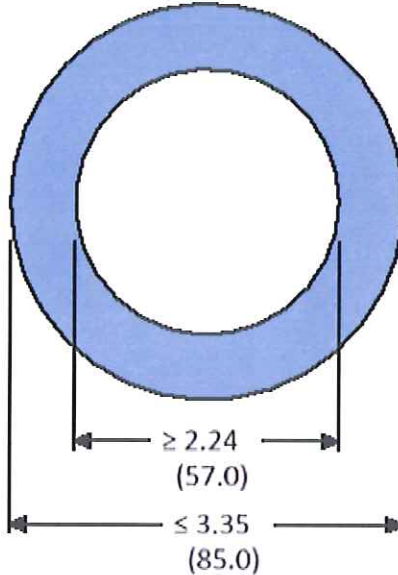

Dimensions = inches (mm)

Electrical Core Performance

Permeability @ frequency = 10 KHz and Hpeak = 3.16 mA/cm ~60,000

Inspection Value	Measured Value	Measurement Limits	Frequency	L _{eff} * N (mA*turn)
	A _L (μH/N ²)	45.8 - 94.5	10 KHz	50
	A _L (μH/N ²)	15.5 min	100 KHz	50

*Saturation Current (Isat) of nanocrystalline material: Peak value of the exiting current when the initial inductance level is dropped to 10 per cent. Saturation behaviour is dependant on frequency, signal shape and leakage field. The current value is a calculated value for design help only and cannot be guaranteed. Isat is calculated @ B = 1.0 T - μnom - N = 1.

Core Finishing

Type:	Plastic Case	Case Material Alternatives:	Zytel FR70G25	Rynite FR530	Longlite 4130	PA66-R11G25
Voltage Breakdown:	2,500 VRMS	Case UL file Number:	E41938	E41938	E59481	E484599

Certification

MH&W International certifies that the manufacturing and the quality process meet all requirements of IEC Part 1: General Specification for "Fixed Inductors For Electromagnetic Interference Suppression", IEC 60938-1:1999 + A1:2006. This International Standard is used in lieu of requirements/documents pertaining to UL, CE, CSA, DIN and other individual agencies. The flame insulation rating meets UL-94V-0.

MH&W International certifies the product described herein is in compliance with the Directive 2011/65/EU of the European Parliament and of the council of 8 June, 2011 on the Restriction of the use of Certain Hazardous Substances in Electrical and Electronic Equipment (RoHS2 Directive).

Rev #	Date	Description	Drawing Approval	Drawing Number
1	08/17/17	Initial Issue	Engineering: D. Rollins	N57HP103-428 R2
2	04/05/21	Updated to new datasheet format.	Sales: B. Wilson	